

Application of Photoelectron Spectroscopy to Intramolecular Hydrogen Bonding. 6. The Relative Importance of Electrostatic and Covalent Contributions to the H Bond of H-Bonded Alcohols Containing a Conjugated Olefin as the Electron Donor

R. S. Brown* and Randall W. Marcinko

Contribution from the Department of Chemistry, University of Alberta, Edmonton, Alberta, Canada, T6G 2G2. Received February 8, 1977

Abstract: In order to assess the relative importance of electrostatic and covalent contributions to the H bond, the photoelectron spectra of several intramolecularly H-bonded olefinic alcohols in which a conjugated diene serves as the electron donor were obtained. If one assumes the validity of Koopmans' theorem, these spectra indicate that upon H-bond formation both symmetric and antisymmetric occupied orbitals of the conjugated system shift to higher ionization energy by the same amount. Since covalent contributions require interaction between like-symmetry orbitals on the olefin and O-H units, the results indicate that such covalent interaction is negligible or exactly compensatory. Assuming that the π -H bond is analogous in nature to the normal lone pair H bond, and using the above criterion, the H bond is best described in electrostatic terms which require little covalent interaction.

I. Introduction

The phenomenon of hydrogen bonding continues to be of great experimental and theoretical interest.¹ A convenient representation of the H bond in valence bond terms involves consideration of structures such as those in 1²

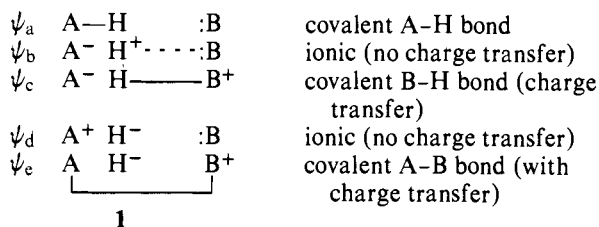

so that the total H-bond wave function (ψ_H) is

$$\psi_H = a\psi_a + b\psi_b + c\psi_c + d\psi_d + e\psi_e \quad (1)$$

Coulson's calculation of the H-bond energy based on structures ψ_a , ψ_b , and ψ_c indicated that the bond is essentially electrostatic, with the covalent contribution (of ψ_c) amounting only to a few percent.^{2a,b} Tsubomura,^{2c} including additional structures of ψ_d and ψ_e , found a "delocalization energy" which is "of the same order of magnitude or rather larger than the electrostatic energy" represented by ψ_a , ψ_b , and ψ_d . Later Coulson pointed out in a review^{2a} that the H-bond energy can be divided into four components, electrostatic, delocalization, dispersion, and repulsive forces all of which are important and must be considered

In later years, molecular orbital treatments of the H-bond augmented the earlier valence bond treatments,³ and the question of partitioning the H-bond energy into various electrostatic and covalent components was again addressed.^{3b,c,e} The approach of Morokuma^{3b,c} divides the total energy of the H bond (E_H) into four components where $E_{es} + E_{pd}$ represent energy changes (stabilizing) arising from classical Coulombic effects, E_{ex} represents the exchange repulsion energy (destabilizing), and E_{ct} represents the (stabilizing) charge transfer energy.⁴ For the systems studied ($H_2O \cdot H_2O$; $H_2O \cdot OCH_2$; $H_2O \cdot \text{cyclopropanone}$), $E_{es} + E_{pd}$ contributed the largest stabilizing component, while E_{ex} with a somewhat smaller absolute value was destabilizing, and E_{ct} was stabilizing, but smaller yet.

$$E_H = E_{es} + E_{pd} + E_{ex} + E_{ct} \quad (2)^{3b,c}$$

It should be pointed out that the easily visualized valence bond structures of 1 as well as the MO treatment used to evaluate eq 2 require for their individual covalent or delocalization components, the correct symmetry of the interacting orbitals on the electron donor (B:) and proton donor (A—H), while the Coulombic or electrostatic components are essentially free from this restriction.

To date, attempts to experimentally assess the relative amounts of electrostatic and covalent contributions to the H bond have, to our knowledge been limited to the ¹⁴N NMR shifts reported by Saito et al.,⁵ for pyridine in methanol solution. Considering structures ψ_a , ψ_b , and ψ_c in eq 1, these workers were able to place a value of $7 \pm 3\%$ for the contribution of ψ_c , in good agreement with their calculated value and that originally reported by Coulson.^{2b}

Recently we reported the use of UV photoelectron spectroscopy (PES) to determine H bond induced shifts in the ionization energies (IP) of valence electrons intimately involved in H-bond formation, compared with those in geometric isomers in which no H bond could be formed.⁶ The results for amino alcohols, α -hydroxy ketones and *syn*- and *anti*-7-norbornenol showed that the IP of B: became larger and the IP of H—Ö became lower on H-bond formation. Subsequently, we

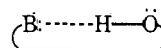

felt that certain bicyclic conjugated olefins in which the electron donor π -system contained orbitals of differing symmetry oriented favorably for H-bond formation might offer a unique model system for assessing the relative importance of electrostatic and covalent contributions to the H-bond interaction. To this end, we have prepared and determined the PE spectra of compounds 2–14. The following represents our findings concerning this question.

II. Experimental Section

The PE spectra were determined using a MacPherson Model 36 ESCA spectrometer with He(I) radiation. Samples were introduced as vapors along with internal calibrants of Ar or N₂; the resolution of the Ar $2P_{1/2}$ – $2P_{3/2}$ doublet was 25–35 MeV while operating. Routine IR and PMR spectra were recorded using a Perkin-Elmer 421 grating infrared spectrometer and a Varian A56-60 spectrometer,

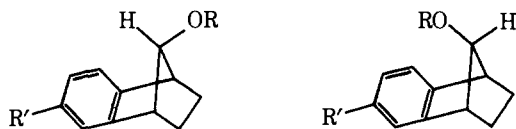

- 2 R = R' = H
3 R = CH₃; R' = H
4 R = H; R' = CH₃

- 5 R = R' = H
6 R = CH₃; R' = H
7 R = H; R' = CH₃



- 8 X = OH; Y = H
9 X = H; Y = OH

- 10 X = OH; Y = H
11 X = H; Y = OH

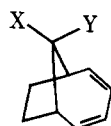

- 12 X = OH; Y = H
13 X = H; Y = OH
14 X = H; Y = OCH₃

respectively. A Varian Associates HA-100 spectrometer was used to determine 100-MHz spectra. All melting and boiling points are uncorrected.

anti-7-Benzonorbornenol and syn-7-Benzonorbornenol (2 and 5). Reduction of 7-benzonorbornenone according to the procedure of Tanida, Tsuji, and Ishitobi⁷ followed by column chromatography (Florisil 30:1) eluted with ether-petroleum ether (1:10) yielded *anti*-7-benzonorbornenol (**2**), mp 102.5–103.5 °C (lit.⁷ 104–105 °C) followed by *syn*-7-benzonorbornenol (**5**), mp 114–114.5 °C (lit.⁷ 117 °C).

anti-7-Methoxybenzonorbornene (3). Methylation of 0.50 g (3.1 × 10⁻³ m) of **2** (prepared as above) by the procedure of Diner, Sweet, and Brown⁸ yielded after final workup and molecular distillation (120 °C/3.5 Torr), 0.22 g (41%) of **3**; ¹H NMR (CDCl₃) δ 7.14 (s (br), 4H), 3.35 (s (br), 4H, CH₃O and H-C-O-), 3.25 (m, 2H), 1.88–1.14 (m, 2H), 1.21–0.98 (m, 2H); IR (CHCl₃) 2975, 2940, 2890, 2825, 1460, 1358, 1338, 1298, 1288, 1100, 1010, 980 cm⁻¹. *Exact Mass* calcd for C₁₂H₁₄O: 174.1045; found: 174.1049. Anal. Calcd for C₁₂H₁₄O: C, 82.72; H, 8.10; found: C, 82.49; H, 8.19.

syn-7-Methoxybenzonorbornene (6). Methylation⁸ of 0.5 g (3.1 × 10⁻³ m) of alcohol **5** followed by the usual workup and molecular distillation (120 °C/3.5 Torr) yielded 0.490 g (91%) of ether **5**, ¹H NMR (CDCl₃) δ 7.14 (m, 4H), 3.78 (t, *J* = 1.5 Hz, 1 H), 3.33 (m, 2 H), 3.21 (s, 3 H), 2.08–1.84 (m, 2 H), 1.21–1.04 (m, 2 H); IR (CHCl₃) 2980, 2940, 2880, 2830, 1455, 1360, 1320, 1275, 1140, 1115, 1090, 1080, 1004 cm⁻¹. *Exact Mass* calcd for C₁₂H₁₄O: 174.1046; found: 174.1046. Anal. calcd for C₁₂H₁₄O: C, 82.72; H, 8.10; found: C, 82.75; H, 8.37.

anti-4'-Methyl-7-benzonorbornenol (4). Reduction of 4'-methyl-7-benzonorbornenone⁹ with NaBH₄ in CH₃OH followed by addition of water, and pentane extraction, yielded after removal of the solvent the *anti* alcohol (**4**) in nearly quantitative yield, mp 94–95 °C (lit.⁷ 95–96 °C).

syn-4'-Methyl-7-benzonorbornenol (7). To a mixture of 1.95 g (0.2 equiv) of NaBH₄ in 70 mL of dry diglyme (bis-2-(methoxyethyl) ether) cooled to 0 °C and containing 10.09 g (0.14 m) of 2-methyl-2-butene was added 9.68 g of freshly distilled BF₃·OEt₂ complex. After the mixture formed a solution (~15 min) 5.09 g (0.03 m) of 4'-methyl-7-benzonorbornenone⁹ in 20 mL of dry diglyme was added and the solution was stirred at 0° for 3 h, and then overnight at room temperature. Workup consisted of addition of 60 mL of 3 N NaOH, followed by 45 mL of 30% H₂O₂, and then multiple extraction of the mixture with ether. The combined ether extracts were dried over MgSO₄ and solvent removed to yield 4.25 g (83%) of a white solid which proved to be a mixture of *syn* and *anti* alcohols in a ratio of ~2:1. Separation of **4** and **7** was accomplished by preparative GLPC

(Carbowax 20 M on Chromosorb W, 60/80 mesh, 180 °C) to yield **4** followed by **7**, mp 87.5–88 °C, ¹H NMR (CDCl₃) δ 7.26–6.90 (m, 3 H), 4.13 (d, *J* = 8 Hz, 1 H), 3.13 (m, 2 H), 2.34 (s, 3 H), 2.08–1.86 (m, 2 H), 1.53 (d, *J* = 8 Hz, 1 H, exchangeable in D₂O), 1.21–1.02 (m, 2 H); IR (Cl₂C=CCl₂) 3565, 3020, 2970, 2950, 2870, 1510 (br) 1470, 1458, 1400, 1265, 1205, 1140, 730, and 665 cm⁻¹. *Exact Mass* calcd for C₁₂H₁₄O: 174.1046; found: 174.1046. Anal. calcd for C₁₂H₁₄O: C, 82.72; H, 8.12; found: C, 82.90; H, 8.17.

anti- and syn-Bicyclo[4.2.1]non-3-en-9-ol (8 and 9). Reduction of 3 g (0.02 m) of bicyclo[4.2.1]non-3-en-9-one⁹ using the procedure of Diaz et al.,^{10,11} followed by column chromatography of the reaction products using Florisil (30:1) with 95:5 petroleum ether-ether yielded 1.3 g of *syn* alcohol **9**, mp 80–83 °C, ¹H NMR (CDCl₃) δ 5.51 (m, 2 H), 4.31 (t (br), *J* = 7 Hz, 1 Hz), 2.36–2.06 (m, 5 H), 2.06–2.14 (m, 6 H); IR (CCl₄) 3620, 3590, 3010, 2950, 2910, 2830, 1653, 1458, 1440, 1425, 1395, 1255, 1193, 1151, 1130, 1075 (br), 990, 650 cm⁻¹. *Exact Mass* calcd for C₉H₁₄O: 138.1047; found, 138.1040. Anal. calcd for C₉H₁₄O: C, 78.21; H, 10.21; found: C, 77.84; H, 10.22.

Further elution of the column with 90:10 petroleum ether-ether yielded 0.6 g of a mixture of *syn* and *anti* alcohols followed by 0.8 g of *anti* alcohol **8**, mp 72.5–75 °C, ¹H NMR (CDCl₃) δ 5.50 (s (br), 2 H), 3.93 (s, 1 H), 2.42–1.84 (m), 1.75–1.20 (m), IR (CCl₄) 3620, 3010, 2950 (br), 2910, 2830, 1653, 1458, 1440, 1427, 1360, 1332, 1280, 1178 (br), 1030, 950, 900, 855, 662 cm⁻¹. *Exact Mass* calcd for C₉H₁₄O: 138.1047; found: 138.1045. Anal. calcd for C₉H₁₄O: C, 78.21; H, 10.21; found: C, 77.84; H, 10.20.

anti- and syn-Bicyclo[2.2.2]oct-2-en-5-ol (10 and 11). Reduction of 2.44 g (0.02 m) of bicyclo[2.2.2]oct-2-en-5-one¹² with 0.30 g (0.009 m) of NaBH₄ in 20 mL of CH₃OH stirred for 1 h followed by addition of 100 mL of H₂O, and extraction with pentane which was then dried over MgSO₄ yielded after solvent removal 2.4 g (95%) of a crystalline mass which proved to be a 2:1 mixture of alcohols **10** and **11**. Column chromatography of the mixture over 100 g of Florisil eluted with 95:5 petroleum ether-ether yielded first the *anti* alcohol **10**, mp 166–168.5 °C (lit.¹³ 175–176 °C) followed by the *syn* alcohol **11**, mp 160–161 °C (lit.¹⁴ 167.5–169 °C).

anti-Bicyclo[4.2.1]nona-2,4-dien-9-ol (12). Treatment of bicyclo[4.2.1]non-3-en-9-one¹⁰ with 2 equiv of *N*-bromosuccinimide in CCl₄ according to the procedure of Schuster and Kim¹⁵ followed by treatment with Zn-HOAc yielded, after the described workup,¹⁵ 35% of an oil which proved to be bicyclo[4.2.1]nona-2,4-dien-9-one. *Exact Mass* calcd. for C₉H₁₀O: 134.0732; found: 134.0732.

Reduction of 2.0 g (0.0149 m) of bicyclo[4.2.1]nona-2,4-dien-9-one by the procedure of Diaz et al.¹¹ using 10 g of Al(O*i*Pr)₃ and 0.1 mL of acetone in 100 mL of xylene yielded after workup¹¹ 1.7 g of a yellow oil which was chromatographed over Florisil (75 g) using 95:5 petroleum ether-ether. The elution yielded first the *anti* alcohol (**12**) mixed with a small amount of *syn*, to give a total weight of 1.34 g (65%). Preparative GLPC (Carbowax 20 M on Chromosorb W, 60/80 mesh, 10 ft, 180 °C) of a small sample yielded the two alcohols with *anti* one (**12**) predominating, as a clear oil, ¹H NMR (CDCl₃) δ 5.91–5.46 (m, 4 H), 4.64 (s, 1 H), 2.42–2.20 (m, 2 H), 2.38–1.90 (m, 4 H), 1.62 (s (br), 1 H, exchangeable with D₂O); IR (CCl₄) 3620, 3025, 2940, 2875, 1455, 1435, 1375, 1210, 1085, 1030, 1000, 930, 865 and 685 cm⁻¹. *Exact Mass* calcd for C₉H₁₂O: 136.0888; found: 136.0886.

syn-Bicyclo[4.2.1]nona-2,4-dien-9-ol (13). Reduction of 0.6 g (0.004 m) of bicyclo[4.2.1]nona-2,4-dien-9-one (prepared as above) with 300 mg of NaBH₄ in 15 mL of CH₃OH for 15 min followed by the addition of 20 mL of H₂O gave a solution which was multiply extracted with pentane. Drying of the combined pentane extracts over MgSO₄ followed by removal of solvent yielded an oil which was molecularly distilled at 100 °C (6 Torr) to afford 0.5 g (82%) of exclusively *syn* alcohol **13**, ¹H NMR (CDCl₃) δ 6.06–5.62 (m, 4 H), 4.64–4.33 (d of t, *J* = 12 Hz, 6 Hz, 1 H), 2.73 (s (br), 2 H), 2.22 (d, *J* = 12 Hz, 1 H, exchangeable with D₂O), 2.03–1.26 (m, 4 H); IR (CCl₄) 3565, 3020, 2940, 2870, 1455, 1435, 1390, 1350, 1235 (br), 1160, 1080, 1060, 880, 860 and 692 cm⁻¹. *Exact Mass* calcd for C₉H₁₂O: 136.0888; found: 136.0884.

syn-9-Methoxybicyclo[4.2.1]nona-2,4-diene (14). Methylation⁸ of 0.5 g (0.004 m) of *syn* alcohol **13** with 318 mg of NaH (57% suspension washed with dry ether to remove oil) in 20 mL of dry DME containing 1 mL of CH₃I yielded after workup⁸ and molecular distillation (100 °C/6 Torr) 0.4 g (70%) of ether **14**, ¹H NMR (CDCl₃) δ 5.82 (m, 4 H), 4.04 (s, *J* = 6 Hz, 1 H), 3.32 (s, 3 H), 2.78 (s (br), 2 H), 2.00–1.90 (m, 4 H); IR (CHCl₃) 2930 (br), 2860, 2830, 1590, 1450

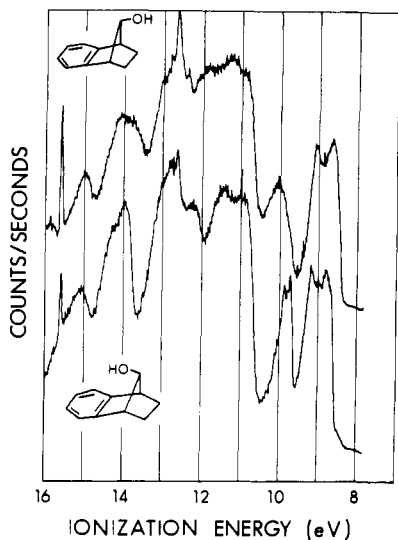

Figure 1. The PE spectra of *anti*- and *syn*-7-benzonorbornenol (2 and 5) using nitrogen as a calibration gas.

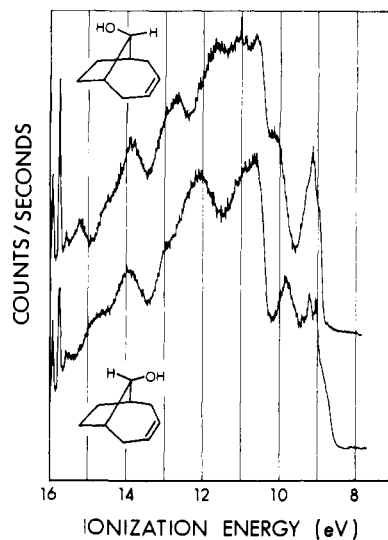

Figure 4. The PE spectra of *anti*- and *syn*-bicyclo[4.2.1]non-3-en-9-ol (8 and 9) using argon as an internal calibrant.

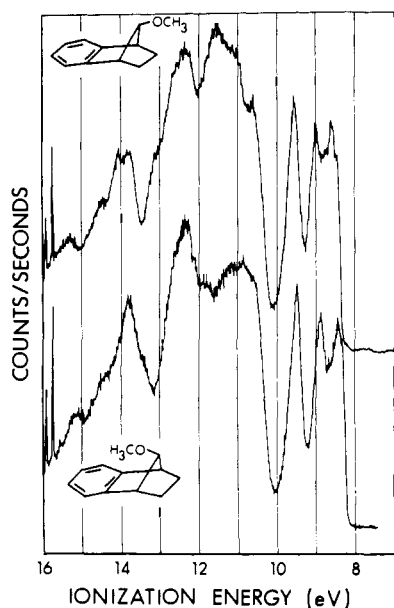

Figure 2. The PE spectra of *anti*- and *syn*-7-methoxybenzonorbornene (3 and 6) using argon as an internal calibrating gas.

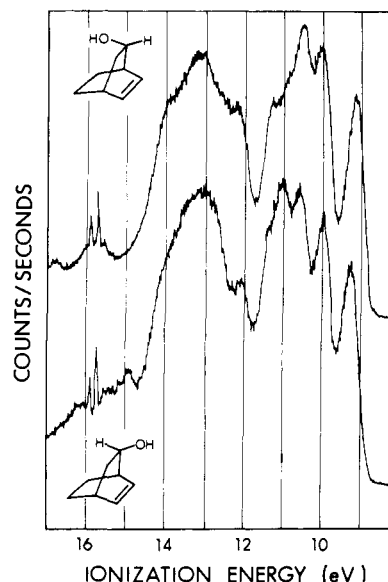

Figure 5. The PE spectra of *anti*- and *syn*-bicyclo[2.2.2]oct-2-en-5-ol (10 and 11) using argon as an internal calibrant.

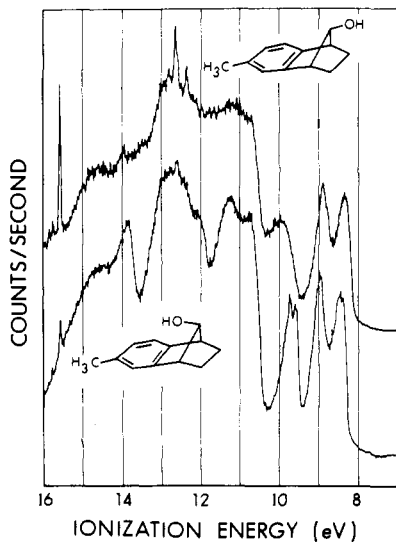

Figure 3. The PE spectra of *anti*- and *syn*-4'-methyl-7-benzonorbornenol (4 and 7) using nitrogen as an internal calibrant.

(br), 1355, 1118, 1098, 1012, 975, and 865 cm^{-1} . *Exact Mass* calcd for $\text{C}_{10}\text{H}_{14}\text{O}$: 150.1045; found: 150.1043.

III. Results and Discussion

The PE spectra of compounds 2–14 are presented in Figures 1–7 and the corresponding vertical ionization energies (IP) and assignments presented in Tables I and II.

Perusal of the data reveals the following unifying feature exhibited for each pair of *anti* and *syn* alcohols. All the *syn* alcohols in which the geometry allows interaction between the π -system and the OH bond have higher π -IP's and lower oxygen (n_{OR}) IP's than the corresponding *anti* isomer in which H-bonding is precluded. While the observation has been made for a variety of systems,^{6,16} the present olefins offer unique symmetry characteristics which should be useful in assessing the relative importance of electrostatic and covalent interactions.

It is important to ascertain that the π -H bond does not represent a unique type of interaction such as a " π -complex", but is indeed a typical H bond. Experimentally, intramolecular interaction of olefins with OH groups has been observed by IR

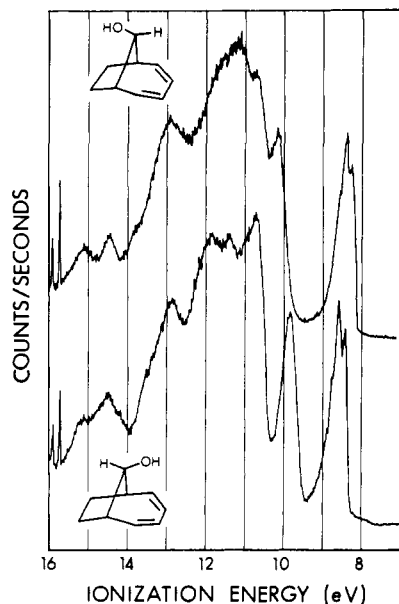

Figure 6. The PE spectra of *anti*- and *syn*-bicyclo[4.2.1]nona-2,4-dien-9-ol (**12** and **13**) using argon as an internal calibrant.

Table I. Vertical Ionization Energies (IP) and Assignments for Compounds 2–7

Compound	Ionization energy, eV		
	n_{OR}^a	π_2^b	π_3^c
<i>anti</i> -7-Benzonorbornenol (2)	9.99	9.04	8.62
<i>syn</i> -7-Benzonorbornenol (5)	9.86	9.18	8.80
	($\nu^+ = 1202 \pm 50 \text{ cm}^{-1}$)		
<i>anti</i> -7-Methoxybenzonorbornene (3)	9.56	9.03	8.61
<i>syn</i> -7-Methoxybenzonorbornene (6)	9.46	8.90	8.46
<i>anti</i> -4'-Methylbenzonorbornenol (4)	9.95	8.87	8.31
<i>syn</i> -4'-Methylbenzonorbornenol (7)	9.75	9.02	8.41

^a Predominantly oxygen lone pair, antisymmetric with respect to reflection through a mirror plane bisecting the molecule. ^b Assigned as predominantly aromatic, and is antisymmetric with respect to reflection through a mirror plane bisecting the molecule. (Strictly true only for compounds **2**, **3**, **5**, and **6**.) ^c Assigned as predominantly aromatic and is symmetric with respect to reflection through a mirror plane bisecting the molecule. (Strictly true only for compounds **2**, **3**, **5**, and **6**.)

spectroscopy,¹⁷ microwave spectroscopy,¹⁸ and mass spectrometry,¹⁹ and the interpretation of the results indicates a rather weak association not unlike a typical H bond. Theoretically, relatively few calculations have been performed on π -H-bonded systems;²⁰ however, the results are in substantial agreement with those for lone pair H bonds. For example, ab initio calculations by Del Bene^{20a} on dimers involving HF or H₂O and the π systems of ethylene, acetylene, hydrogen cyanide, and formaldehyde show that with the symmetrical hydrocarbons, a relatively weak association (≤ 1 kcal/mol) occurs at or near the midpoint of the C–C– π bond. With polar π bonds as the proton acceptors (i.e., HC \equiv N or H₂C=O) association occurs preferentially at the negative end of the π system, but this arrangement is not an equilibrium structure, since H-bond formation at the lone pair is calculated to be of lower energy.²⁰ CNDO/2 calculations including the same systems^{20b,c} and larger ones such as benzene–HF^{20d,f} and *syn*-7-norbornenol^{20e} have also been performed but the method generally tends to

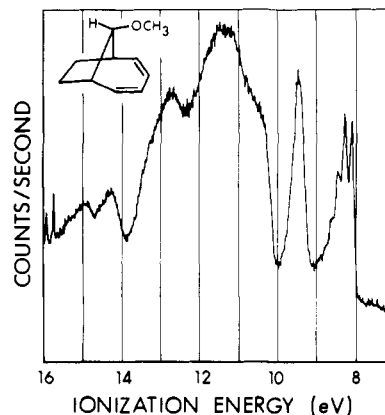

Figure 7. The PE spectrum of *syn*-9-methoxybicyclo[4.2.1]nona-2,4-diene (**14**) using argon as an internal calibrant.

Table II. Vertical Ionization Energies (IP) and Assignments for Compounds 8–14

Compound	Ionization energy, eV	
	n_{OR}	π^a
<i>anti</i> -Bicyclo[4.2.1]non-3-en-9-ol (8)	10.06	9.11
<i>syn</i> -Bicyclo[4.2.1]non-3-en-9-ol ^b (9)	9.81	9.14
<i>anti</i> -Bicyclo[2.2.2]oct-2-en-5-ol (10)	10.00	9.14
<i>syn</i> -Bicyclo[2.2.2]oct-2-en-5-ol (11)	9.94	9.25
<i>anti</i> -Bicyclo[4.2.1]nona-2,4-dien-9-ol (12)	10.19	8.43
		($\nu^+ = 1437 \pm 50 \text{ cm}^{-1}$)
<i>syn</i> -Bicyclo[4.2.1]nona-2,4-dien-9-ol (13)	9.85	8.62
		($\nu^+ = 1357 \pm 50 \text{ cm}^{-1}$)
<i>syn</i> -9-Methoxybicyclo[4.2.1]nona-2,4-diene (14)	9.46	8.28
		($\nu^+ = 1318 \pm 50 \text{ cm}^{-1}$)
<i>anti</i> -7-Norbornenol ^c	10.04	9.19
<i>syn</i> -7-Norbornenol ^c	9.71	9.41

^a π represents ionization from predominantly a π -symmetry orbital located on the carbon framework. For compounds **12**, **13**, and **14** where in principle there are two π -bands (π_S and π_A with respect to the mirror plane bisecting the molecule) only one π -ionization is observed which is assigned π_A . ^b Compound **9** shows both a free and bonded OH in the infrared spectrum, and shows a shoulder on the low energy side of π , presumably attributable to the non-H-bonded conformer π -ionization. ^c Reference 6.

overestimate the H-bond energy and predict different geometries for the polar π -H bond than the ab initio technique. It seems evident that the computational results can best be analyzed in terms of a π -H bond which is in nature similar to, but weaker than, a normal lone pair H bond. The weakness of the H-bond interaction in these systems may reflect the absence of localized charge regions within the proton acceptor.^{20a}

Our approach to the problem of distinguishing electrostatic from delocalization (covalent) effects involved the assumption that the former effect depends heavily on the internuclear distance between the interacting components but is independent of their orbital symmetry,^{21,22} while the latter effect relies both upon internuclear separation and orbital symmetry. Thus we measured the influence of the H bond on the ionization energies of orbitals of differing symmetry within a conjugated π system. Figure 8 illustrates the expected shifts for compound **5** in the absence of inductive or electrostatic effects.

The two highest aromatic orbitals of both **2** and **5** are symmetric (S) and antisymmetric (A) relative to a plane bisecting the molecule. According to Murrell,^{3e} perturbation arguments indicate that ground-state stabilization of the electron donor

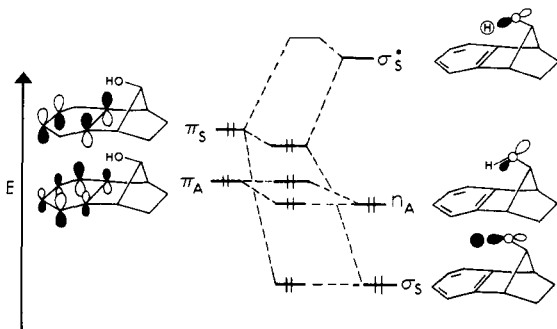

Figure 8. A correlation diagram for *syn*-7-benzonorbornenol (**4**) illustrating the expected interaction between the two highest occupied ring orbitals (ref 23) and the localized H–O orbitals assuming symmetry requirements and no inductive effects. (π_A has been included, and while of the correct symmetry to interact with π_A , such interactions in related systems appear to be small or non-existent, see ref 23, 24 and text.)

occurs via interaction with higher energy unoccupied orbitals of like symmetry on the proton donor. If this is appreciable, then the OH σ^* orbital (S) can only interact with π_S , lowering it in energy, while π_A (except for inductive and/or electrostatic effects) remains unperturbed by the hydroxyl group. Such inductive effects should operate simultaneously on both π_S and π_A .²¹ The net effect is that the separation between π_A and π_S should diminish when the H bond is permitted (i.e., in passing from **2** to **5**).²⁴ The data of Table I clearly show that the separation between π_A and π_S (assuming the validity of Koopmans' theorem)²⁶ remains constant at 0.41 ± 0.02 eV in both **2** and **5** and suggest that orbital interactions such as illustrated in Figure 8 are negligible. It is interesting to note that n_A (oxygen) and π_A apparently do not show different interaction in passing from the anti to syn alcohol since such should raise the energy of π_A in the latter, contrary to what is observed.²⁵

As a further probe for the existence of an important symmetry related component in the π -H bond the 4'-methylbenzonorbornenols (**4** and **7**) were investigated. The 4'-methyl group destroys the local symmetry characteristics of π_A and π_S , and yet the separation between the two highest aromatic orbitals remains constant at 0.56 ± 0.1 eV for both **4** and **7**. This observation also argues against differing orbital interactions in the two isomers, although the identical stabilization of π_A and π_S in **7** is consistent with an increased electrostatic interaction between the ring and hydroxyl.

In order to test the consequences of the different orientations of the oxygen in the absence of H bonding the methyl ethers **3** and **6** were studied. Although no such interaction as that illustrated in Figure 8 is possible, switching from *anti*-**3** to *syn*-**6** reveals a decrease in IP of both π_A and π_S , but their separation remains a constant 0.43 ± 0.02 eV. Destabilization of both orbitals is consistent with different field effects in the syn and anti isomers and argues against an interaction between n_A and π_A in the former since such would be expected to bring π_A and π_S closer together in **6**.²⁴

A further test for the relative importance of electrostatic and conjugative contributions to the H bond can be envisioned using the *anti*- and *syn*-bicyclo[4.2.1]nona-2,4-dien-9-ols (**12** and **13**, respectively). Figure 9 shows the expected symmetry allowed interactions between the localized HO σ^* -orbital (S) and the butadiene π_S which should serve to increase the separation between π_S and π_A in *syn*-**13** relative to that observed in the anti isomer (**12**). For **13** an additional possibility of interaction exists between π_S and the occupied σ_S OH bond which if important may destabilize π_S . Unfortunately, π_S is buried under the σ envelope for both **12** and **13** and hence we can say nothing about the π_S - π_A separation. However, it is to be noted that π_A in **13** is stabilized by ~ 0.20 eV relative to that

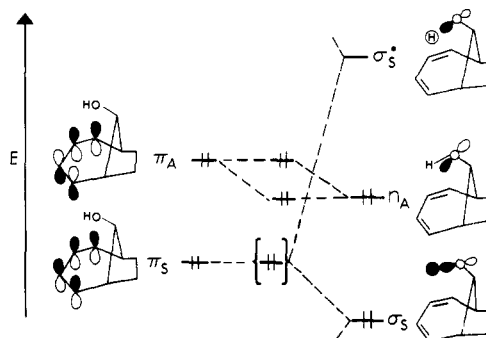

Figure 9. A correlation diagram for *syn*-bicyclo[4.2.1]nona-2,4-dien-9-ol (**13**) assuming symmetry permitted interactions in the absence of inductive and electrostatic effects. (The HOMO is π_A , predominantly located on the carbon framework, while the next occupied orbital is n_A , localized on the oxygen.)

in **12** which can only result from symmetry independent electrostatic or inductive effects in the syn isomer. The possibility of a dominant destabilization between π_A and n_A (OR) can be eliminated since such should serve to destabilize π_A in **13** relative to that in **12**. By way of reference, π_A in the non-H-bonding *syn*-9-methoxybicyclo[4.2.1]nona-2,4-diene (**14**) is easier to ionize than its counterpart in **12** or **13** by 0.16 and 0.35 eV, respectively.

We feel that the above results are most compatible with an H bond which is predominantly electrostatic in nature.^{2a,b} In each of the syn alcohols an intramolecular H bond could be demonstrated by conventional IR techniques which showed a concentration independent bonded OH stretch at 3575 ± 15 cm^{-1} . Two of these, *syn*-bicyclo[2.2.2]oct-2-en-5-ol (**11**) and *syn*-bicyclo[4.2.1]non-3-en-9-ol (**9**), show the presence of both a free and bonded OH stretch at high dilution attesting to the weakness of the H bond, while each of the other syn alcohols shows only a bonded OH stretch. The PE data for each syn alcohol show the π ionization energies are higher, and OH ionization energies lower than those of the anti isomers, but separation of the shifts into electrostatic and covalent contributions can only be possible for the conjugated systems.

IV. Conclusions

Several possibilities consistent with the above observations should be considered. While we prefer the first two rationalizations on the basis of their simplicity, we do not have evidence which allows unambiguous differentiation between all possibilities.

1. Within experimental accuracy, symmetry dependent (covalent) contributions to the H bond are of minimal importance in these systems. We judge the accuracy in determining the peak positions to be ± 0.02 eV over several determinations; symmetry-dependent shifts of this magnitude would not be detectable. This does not mean that charge transfer (which relies upon symmetry correct interactions) is nonexistent in all cases. Mulliken population analyses of several H-bonded systems^{3a,d,27} show small but significant charge transfer from the electron donor to proton donor fragments which must result from orbital interaction, but apparently such need not be large.

2. It has been calculated that upon H-bond formation all orbitals localized on the electron donor are stabilized while those on the proton donor are destabilized regardless of their symmetry.²⁸ This finding is suggested to be a consequence of decreased and increased electron-electron repulsion, respectively, and is predicted to be a general finding for electron donor-acceptor complexes.²⁸ Experimental support for this comes from changes in the N_{1S} and O_{1S} binding energies which

increase and decrease, respectively, on H-bond formation in cyclic 1,2-amino alcohols.²⁹

3. Symmetry dependent interactions may be occurring, but they are exactly compensatory. In other words, for the above models, π_S may be stabilized by the $\sigma^*-\text{OH}$ interaction but exactly destabilized by additional mixing with lower lying filled orbitals ($\sigma-\text{OH}$). While this is roughly equivalent to setting $E_{\text{ex}} + E_{\text{ct}} = 0$ in eq 2, we view this as an unlikely fortuitous event to be occurring in both 5 and 7.

4. Very recently, Morokuma has reported a detailed energy decomposition study of the origin of the H bond,³⁰ using sophisticated ab initio techniques for a variety of dimeric species. As a general rule, the calculations show that behind electrostatics, charge transfer (CT) is usually the second largest attractive force, and is particularly important for the stabilization of weaker H bonds.³⁰ However, for the water dimer it is calculated that the CT interaction causes *all* the orbitals of the electron donor to decrease and those of the proton donor to increase in energy regardless of their symmetry. Thus a paradox exists in comparing the theoretical with our experimental results inasmuch as we have assumed that the CT phenomenon is symmetry dependent. We speculate that it is possible that CT may occur only between symmetry correct orbitals which thereby alters the local electron distributions leading to the observed and calculated orbital energies.³¹ Further study is required to test the above.

Acknowledgment. The authors gratefully acknowledge the financial support of the University of Alberta and the National Research Council of Canada.

References and Notes

- (1) (a) M. D. Joesten and L. J. Schaad, "Hydrogen Bonding", Marcel Dekker, Inc., New York, N.Y., 1974; (b) G. C. Pimentel and A. L. McClellan, "The Hydrogen Bond", W. H. Freeman, San Francisco, Calif., 1960; (c) S. N. Vinogradov and R. H. Linnell, "Hydrogen Bonding", Van Nostrand-Reinhold Co., New York, N.Y., 1971.
- (2) (a) C. A. Coulson, *Research (London)*, **10**, 149 (1957); (b) C. A. Coulson and U. Danielsson, *Arkiv Fysik*, **8**, 239 (1954); (c) H. Tsubomura, *Bull. Chem. Soc. Jpn.*, **27**, 445 (1954).
- (3) (a) P. A. Kollman and L. C. Allen, *Chem. Rev.*, **72**, 283 (1972); (b) S-i. Yamabe and K. Morokuma, *J. Am. Chem. Soc.*, **97**, 4458 (1975); (c) K. Morokuma, *J. Chem. Phys.*, **55**, 1236 (1971); (d) J. E. Del Bene, *J. Am. Chem. Soc.*, **96**, 5643 (1974); **95**, 5460, 6517 (1973), and references therein; (e) F. B. van Duijneveldt and J. N. Murrell, *J. Chem. Phys.*, **46**, 1759 (1967).
- (4) We will refer to the charge transfer in an H-bonded system B: - - - - H-A as the amount of charge transferred from B to H-A, and not necessarily to simple charge shifts occurring within B or H-A arising from the proximity of their electrostatic fields.
- (5) H. Saito, K. Nakuda, H. Kato, T. Yonbezawa, and K. Fukui, *Tetrahedron Lett.*, **111** (1965).
- (6) R. S. Brown, *Can. J. Chem.*, **54**, 1929, 3203, 3206 (1976).
- (7) H. Tanida, T. Tsuji, and H. Ishitobi, *J. Am. Chem. Soc.*, **86**, 4904 (1964).
- (8) U. E. Diner, F. Sweet, and R. K. Brown, *Can. J. Chem.*, **44**, 1591 (1966).
- (9) H. Tanida and R. Muneyuki, *J. Org. Chem.*, **31**, 1988 (1966).
- (10) H. Onoue, I. Moritani, and S. I. Murahashi, *Tetrahedron Lett.*, **121** (1973).
- (11) A. Diaz, J. Fulcher, R. Atina, M. Rubio, and J. Reynoso, *J. Org. Chem.*, **40**, 2459 (1975).
- (12) P. K. Freeman, D. M. Balls, and D. J. Brown, *J. Org. Chem.*, **33**, 2211 (1968).
- (13) R. R. Frazer and S. O'Farrell, *Tetrahedron Lett.*, 1453 (1962).
- (14) H. L. Goering, R. W. Greiner, and M. F. Sloan, *J. Am. Chem. Soc.*, **83**, 1391 (1961).
- (15) D. I. Schuster and C. W. Kim, *J. Org. Chem.*, **40**, 505 (1975).
- (16) (a) J. Steichen, J. D. Franklin, and S. Leavell, *J. Chem. Phys.*, **59**, 4313 (1973); (b) R. K. Thomas, *Proc. Roy. Soc. London, Ser. A.*, **331**, 249 (1972); (c) J. S. Wiczorek, T. Koenig, and T. Balle, *J. Electron Spectrosc. Relat. Phenom.*, **6**, 215 (1975).
- (17) (a) H. Iwamura, *Tetrahedron Lett.*, 2227 (1970); (b) A. Allerhand and P. von R. Schleyer, *J. Am. Chem. Soc.*, **85**, 866 (1968); (c) R. K. Bly and R. S. Bly, *J. Org. Chem.*, **28**, 3165 (1965); (d) Y. Armand and P. Arnaud, *Ann. Chim.*, **9**, 433 (1964).
- (18) A. N. Murty and R. F. Curl, *J. Chem. Phys.*, **46**, 4176 (1967).
- (19) K. Pihlaja, J. Jalonen, and D. M. Jordan, *Adv. Mass Spectrom.*, **6**, 105 (1974).
- (20) (a) J. E. Del Bene, *Chem. Phys. Lett.*, **24**, 203 (1974); (b) A. S. N. Murty, G. R. Saini, K. Devi, and S. B. Shah, *Adv. Mol. Relaxation Processes*, **7**, 255 (1975); (c) D. Bonchev and P. Gremaschi, *Gazz. Chim. Ital.*, **104**, 1195 (1974); (d) G. Alagona, R. Cimiriaglia, E. Scrocco, and J. Tomasi, *Theoret. Chim. Acta.*, **25**, 103 (1972); (e) A. Gamba, P. Beltrame, and M. Simonetta, *Gazz. Chim. Ital.*, **101**, 57 (1971); (f) W. Jakubetz and P. Schuster, *Tetrahedron*, **27**, 101 (1971).
- (21) In the related bicyclic system (9-azabicyclo[4.2.1]nona-2,4-diene) the inductive stabilization by the nitrogen bridge on π_A and π_S of the butadiene has been found to be nearly the same (ref 22).
- (22) (a) W. Schäfer, H. Schmidt, A. Schweig, R. W. Hoffmann, and H. Kurz, *Tetrahedron Lett.*, 1953 (1974); (b) H. Schmidt, A. Schweig, A. G. Anastassiou, and H. Yamamoto, *J. Chem. Soc. D*, 218 (1974).
- (23) E. Haselbach and M. Rossi, *Helv. Chim. Acta.*, **59**, 278 (1976).
- (24) π_A in principle can interact with h_A of the OH group which should destabilize the former. However, such interaction must be small since it is not observed in ethers 3 and 6, and related systems (see text and ref 25).
- (25) A. D. Bain, J. C. Bunzelli, D. C. Frost, and L. Weiler, *J. Am. Chem. Soc.*, **95**, 291 (1973).
- (26) T. Koopmans, *Physica*, **1**, 104 (1934).
- (27) A. Johansson, P. Kollman, and S. Rothenberg, *Chem. Phys. Lett.*, **18**, 276 (1973).
- (28) (a) P. A. Kollman and L. C. Allen, *J. Am. Chem. Soc.*, **93**, 4991 (1971); (b) P. A. Kollman, J. F. Liebman, and L. C. Allen, *J. Am. Chem. Soc.*, **92**, 1142 (1970); (c) P. A. Kollman and L. C. Allen, *J. Chem. Phys.*, **51**, 3286 (1969).
- (29) R. S. Brown and D. A. Allison, *J. Am. Chem. Soc.*, **99**, 3568 (1977).
- (30) H. Umeiyama and K. Morokuma, *J. Am. Chem. Soc.*, **99**, 1316 (1977).
- (31) We thank Professor K. Morokuma for private communications concerning the subtleties of this point.